

# 3-SIDED BRIDGE

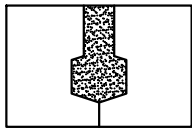

**GROUT JOINT**

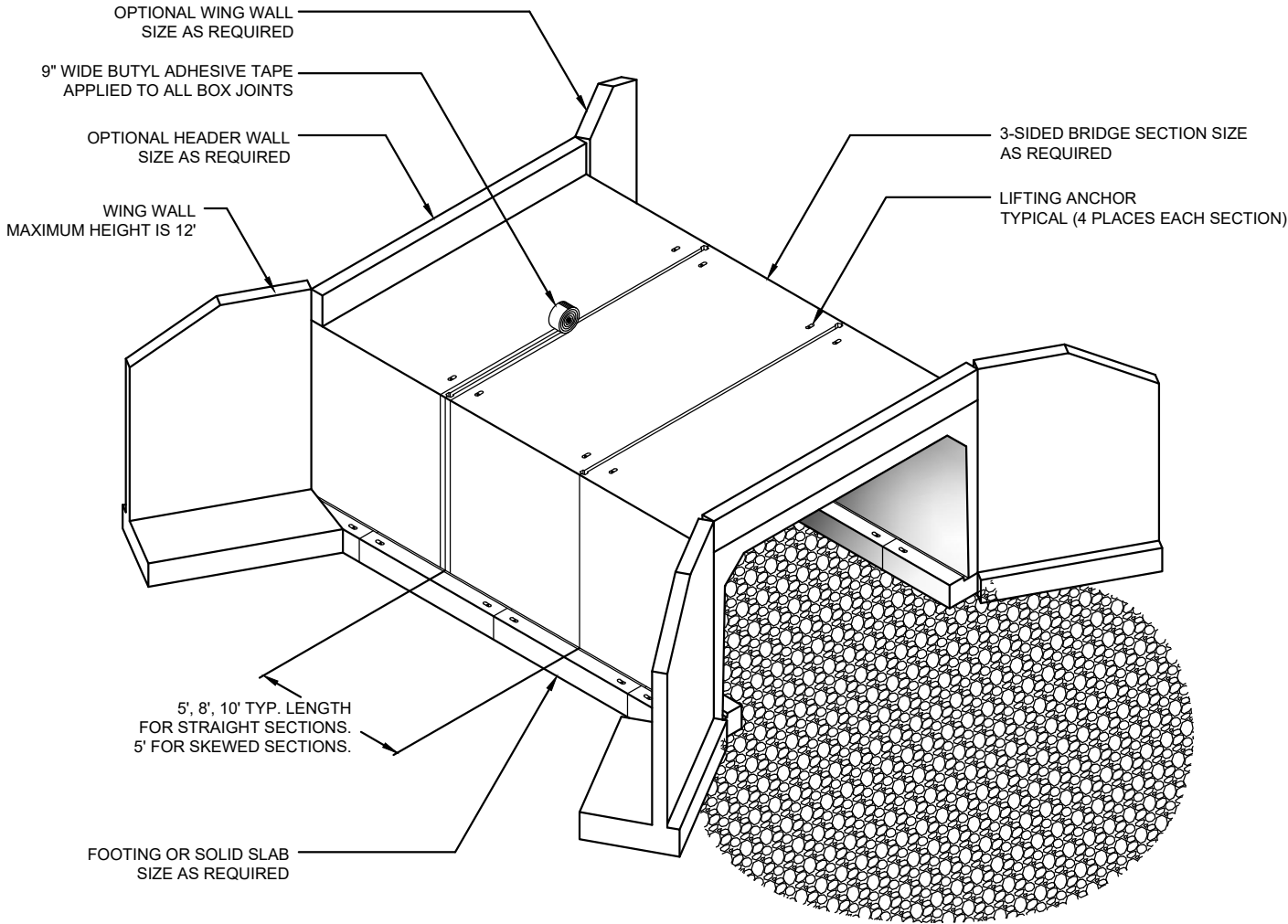
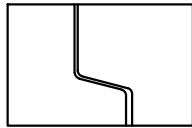

**SHIPLAP JOINT**

NOTE:  
TYPICAL, INSIDE LEG TAPERS 2" IN 103"  
FROM BOTTOM OF HAUNCH TO BOTTOM OF LEG  
(8" WIDE LEG AT BOTTOM FOR 10' HEIGHT)

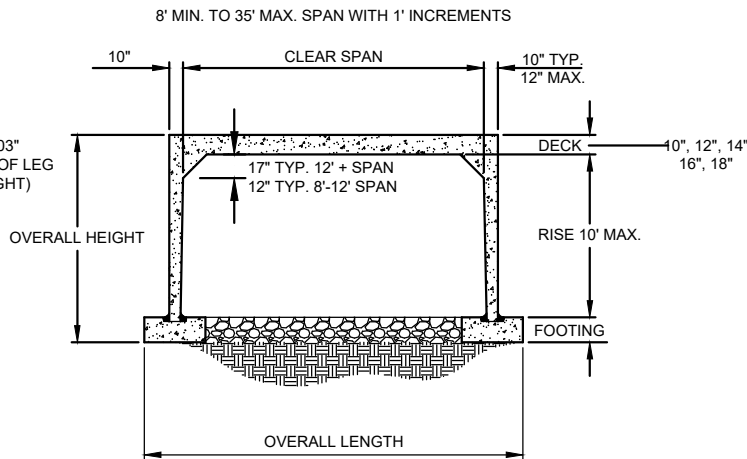

**NOTES:**

1. FOOTING JOINTS TO BE STAGGERED IN RELATION TO BRIDGE JOINTS.
2. WHEN REQUIRED USE NON-SHRINK GROUT CONFORMING TO ASTM C1107.
3. EACH BRIDGE JOINT SHALL BE WRAPPED WITH 9" WIDE BUTYL ADHESIVE TAPE.