

# 1000 OIL WATER SEPARATOR (675)

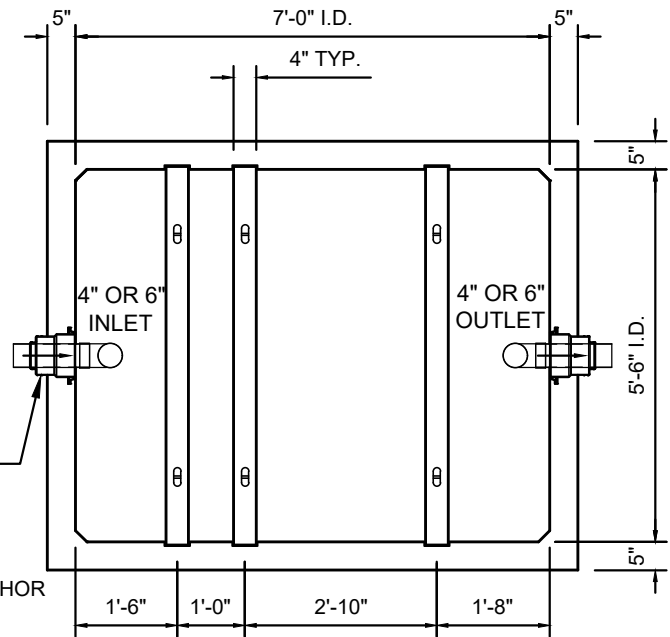

2", 3", 4" AND 6"  
GRADE RINGS  
AVAILABLE AS NEEDED

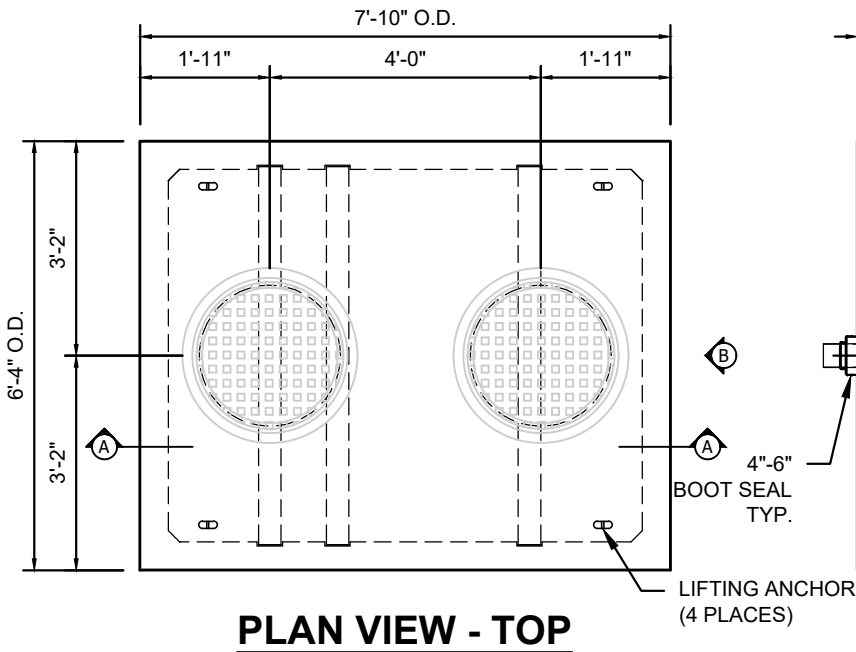
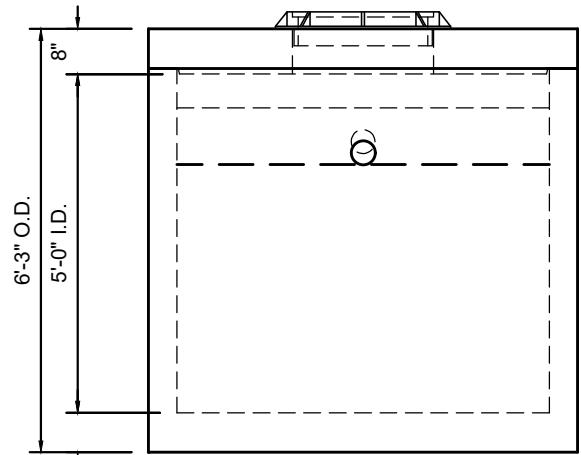
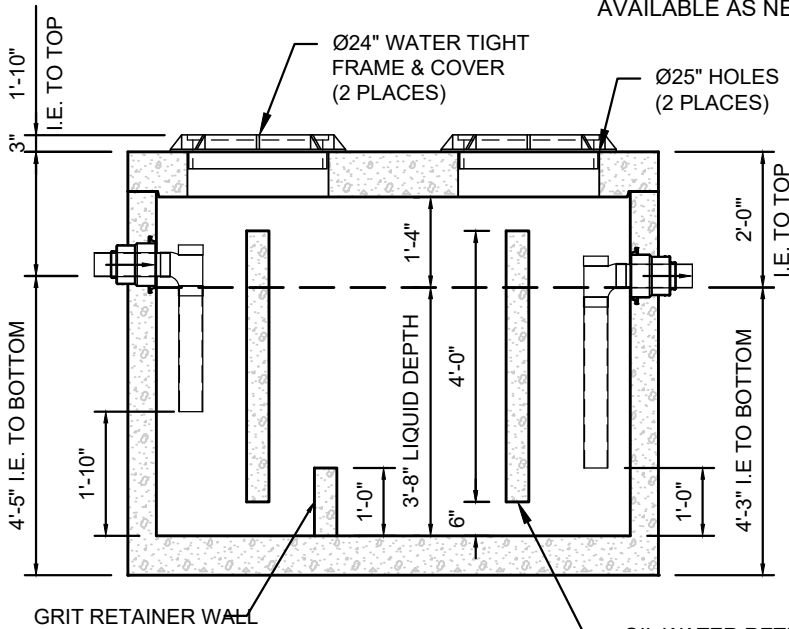

**VIEW-B**  
PIPE AND FITTINGS  
NOT SHOWN FOR  
CLARITY

- NOTES:**
1. HEAVIEST PICK WEIGHT = APPROX. 13,600LBS.
  2. VAULT MEETS OR EXCEEDS ASTM-C857 & H20-44.
  3. 33.6 GPM FLOW RATE AT 30 MINUTE RETENTION.
  4. 288 GALLONS PER VERTICAL FOOT.
  5. 1,000 GALLON CAPACITY AT 3'-6" LIQUID DEPTH.
  6. IT IS THE RESPONSIBILITY OF THE OWNER TO SERVICE THIS UNIT.